

Food Bars

Table Top

Models 6FBRTT - 6 ft. (182 cm), 5FBRTT - 5 ft. (162 cm)
4FBRTT - 4 ft. (130 cm)

Features & Benefits



- Easily turns any 4 - 6 foot (122 - 182 cm) table into a profit producing food bar. Beautifully showcases cold food offerings and/or beverages.
- Will accommodate 3 - 5 each GN 1/1 Full Size Food Pans, and Fractional Size Food Pans with Divider Bars.
- Double-wall polyethylene construction provides extra strength, durability and reliability. Scratch-resistant textured exterior. Simple to clean - just wipe off.
- Thick foamed-in-place polyurethane insulation maintains food temperatures and holds ice cold for hours. Provides added structural strength.
- Drain plug is included to offer quick and easy clean up.
- Standard accessories include protective sneeze guard, made from NSF listed material. Accommodates self-service from both sides.
- Optional accessories include Divider Bars, Crock Holder, and Salad Bowl Holders.
- Non-electrical.
- Easy to assemble.
- Available in 15 colors.

Item No. _____

Specifier Identification No. _____

Model No. _____

Quantity _____



5FBRTT

Set Up Guide for Table Top Food Bars

Salad Bowls and Crock

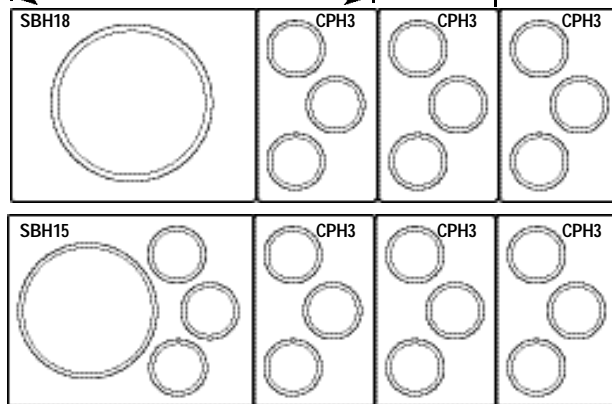
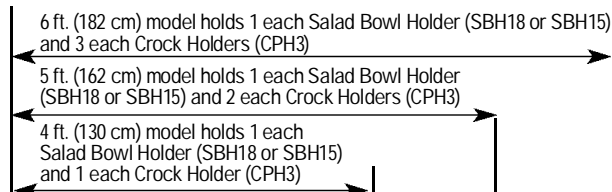

SBH18 - Holds 1 each 18" (45,7 cm) Salad Bowl
SBH15 - Holds 1 each 15" (38 cm) Salad Bowl & 3 each 1.5 qt. (1,4 L) or 2.7 qt. (2, 4 L) Crock
CPH3 - Holds 3 each 1.5 qt. (1,4 L) or 2.7 qt. (2, 4 L) Crock

Food Pans

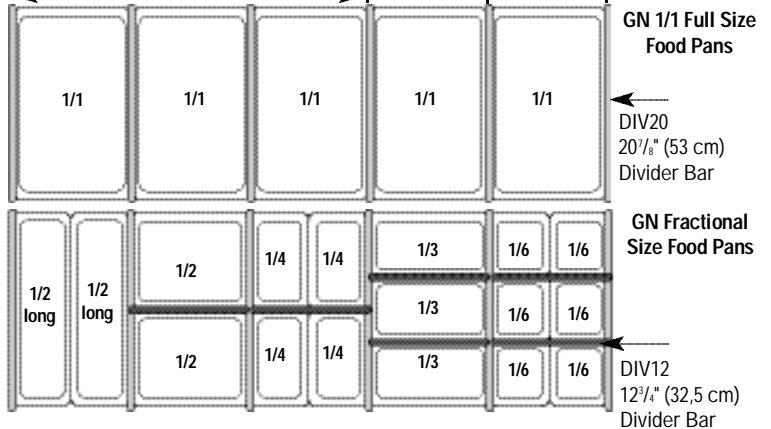
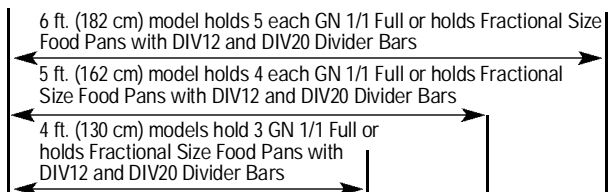

Approvals



Food Bars

Table Top

Models 6FBRTT - 6 ft. (182 cm), 5FBRTT - 5 ft. (162 cm)
4FBRTT - 4 ft. (130 cm)

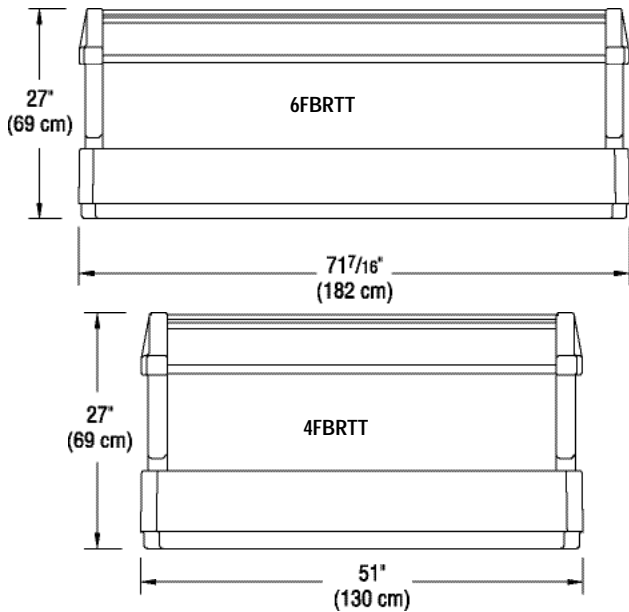

Item No. _____

Specifier Identification No. _____

Model No. _____

Quantity _____

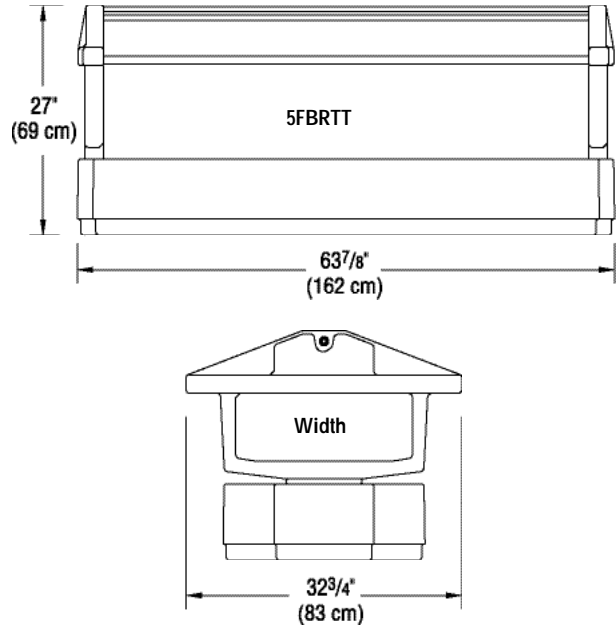

Specifications

Dimension Tolerance: +/- 1/4" (0,64 cm)

Code	Description	GN 1/1 Full Size Food Pan Capacity	Exterior Dimensions L x W x H	Case lbs./cube Kg/m ³
6FBRTT	6 ft. (182 cm) Table Top Food Bar	5	71 7/16" x 32 3/4" x 27" (182 x 83 x 69 cm)	111 (17.57) 50,5 (0,49)
5FBRTT	5 ft. (162 cm) Table Top Food Bar	4	63 7/8" x 32 3/4" x 27" (162 x 83 x 69 cm)	98 (16.26) 45 (0,455)
4FBRTT	4 ft. (130 cm) Table Top Food Bar	3	51" x 32 3/4" x 27" (130 x 83 x 69 cm)	85 (16.26) 39 (0,455)

Optional Accessories

- Divider Bars** DIV12 DIV20
- 3-Crock Holder** CPH3 (holds 1.5 qt. (1,4 L) and 2.7 qt. (2,4 L) crocks)
- Salad Bowl Holders** SBH15 (holds one 15" (38 cm) bowl, 3 crocks)
 SBH18 (holds one 18" (45,7 cm) bowl)

Standard Colors

- Black (110) Slate Blue (401) Brick Red (402)
- Coffee Beige (157) Dark Brown (131) Cold Blue (159)
- Navy Blue (186) Dusty Rose (400) Gray (180)
- Green (519) Hot Red (158) Granite Gray (191)
- Granite Green (192) Granite Red (193) Granite Sand (194)

Divider Bar:

- White (148) Clear (035)

Crock Holder and Salad Bowl Holder:

- White (148)

Architect Specs

The non-electrical foodservice Table Top Food Bar shall be Model..., manufactured by Cambro Mfg. Co., Huntington Beach, CA 92648 U.S.A. It shall be made of double-wall, high-density polyethylene and shall be foam-injected with polyurethane insulation. It shall range in length from 4 - 6 feet (130 - 182 cm). It shall accommodate 3 - 5 each GN 1/1 Full Size Food Pans or Fractional Size Food Pans with Divider Bars. It shall have a drain plug. It shall hold optional Cambro Salad Bowl Holders (SBH18 and SBH15) and Crock Holder (CPH3). The depth of the interior food wells shall be 6 1/2" (16,5 cm). It shall include a sneeze guard and protective end panels made of NSF listed material. It shall require minimal assembly and shall be available in 15 colors.

Approvals

